

# SEG-9SP2TG SECURITY TRANSFER GRILLE

Complies with NIC recommendations and California BoP Title 24

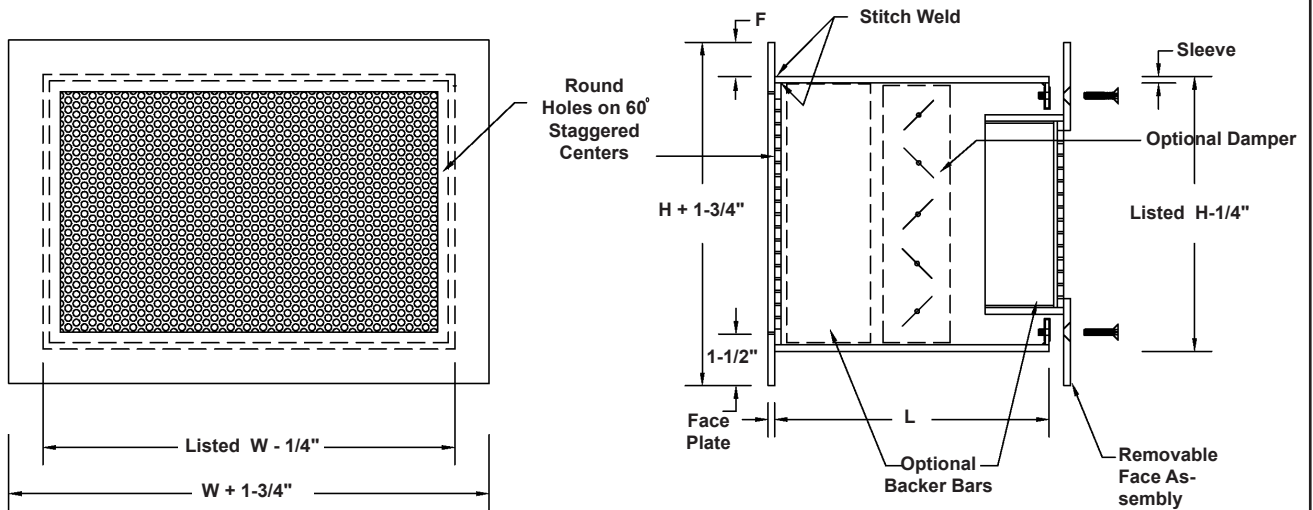

**STANDARD CONSTRUCTION**

**Flange:** 10 ga. steel stitch welded to sleeve. 1" face flange.  
**Face:** .120" thick steel stitch welded to sleeve. 1/8" diameter holes on 3/16" staggered centers.  
**Sleeve:** 10 ga. steel with continuously welded or formed seams.  
**Finish:** Two part polyurethane inside and out. White.

**REQUIRED CONSTRUCTION:**

- Flange Material:**  10 ga. steel (Std.)  
 3/16" steel  
 12 ga. steel  
 Other \_\_\_\_\_
- Face:**  .120" thick with 1/8" dia. holes on 3/16" centers. (Std.)  
 Other \_\_\_\_\_
- Flange "F":**  1" (Std.)  
 Other \_\_\_\_\_
- Sleeve Material:**  10 ga. steel (Std.)  
 3/16" steel  
 12 ga. steel  
 Other \_\_\_\_\_
- Finish:**  White (Std.)  
 Other \_\_\_\_\_

**MOUNTING OPTIONS:**

- 26.** Countersunk screw holes in removable face 10" o.c. with #10-24 x 1" long Torx security machine screws. Screws thread into foldover nuts on 10 ga. steel flange that is stitch welded to sleeve interior.

**ACCESSORIES:**

- 16F.** Opposed blade damper tack welded into sleeve. operable through fixed face. Requires 3/16" dia. hole for access to damper.
- 16R.** Opposed blade damper tack welded into sleeve, operable through removable face. Requires 3/16" dia. hole for access to damper.
- 21.** 2" x 1/4" hot rolled steel vertical backer bars 6" o.c., welded to sleeve.
- Other:** \_\_\_\_\_
- \_\_\_\_\_
- \_\_\_\_\_

Qty.	Listed Size		Sleeve O.D.		Masonry Opening		Sleeve Length L	Wall Thickness	Accessories	Mounting Option	Tag
	W	H	W	H	W	H					

To maintain KEES' policy of continuous product improvement, we reserve the right to change prices, specifications, ratings or dimensions without notice or obligation.

<b>Project</b>			<b>Location</b>		
<b>Architect / Engineer</b>			<b>Contractor</b>		
		Dwg. No.	SEG-9SP2TG 07/18/04		
<b>Representative</b>		Date			



**KEES**

**KEES INCORPORATED**  
 400 S. Industrial Dr.  
 Elkhart Lake, WI 53020  
 Phone: (920) 876-3391  
 Fax: (920) 876-3065  
 Website: www.kees.com